

Slimline LED Flood Light A Series

PHILIPS



Product Features:

- Ultra Slim & Sleek designed body, classic and stylish look, up to 55mm in depth
- Replaces conventional MV and MH light and saving up to 70% energy consumption
- Philips SMD 3030 LED used for higher lumen efficiency and longer lifetime
- Integrated reflector and heatsink design to increase the efficiency of heat dissipation
- Large size PCB and professional optical design for better light distribution and efficiency
- Innovative G-buckle design for fixing glass lens giving elegant appearance, no screws required
- High transparency tempered glass lens used to achieve more than 93% light transmittance
- 3 Year replacement warranty

Application:

- Commercial and residential car parks
- Outdoor security lights
- Under canopy areas and loading bays



Quick Spec

- Luminous Efficacy:** 100 lm/w
- Color temperature:** 2700k-6000K, CRI > 80
- Average rated LED life:** 50,000hrs @ L70
- Ambient temperature:** -35°C to 45°C
- Beam Angle:** 100°

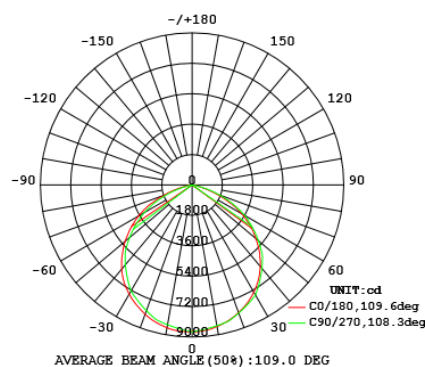
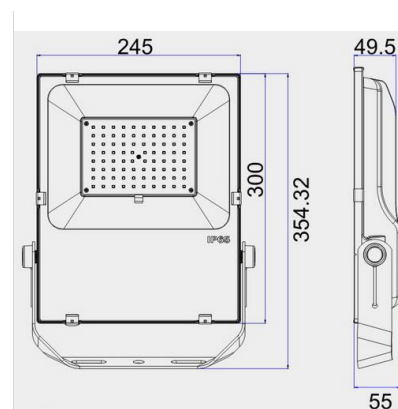

Model	Watts	Supply Volatage	Lumen Output	L*W*H (mm)	Weight	IP Rating
SL-FL-30WA	30W	AC85-265V,50Hz	3000lm	167*200*40	1.3Kgs	IP65
SL-FL-50WA	50W	AC85-265V,50Hz	5000lm	220*265*50	2.3Kgs	IP65
SL-FL-70WA	70W	AC85-265V,50Hz	7000lm	245*300*55	4.0Kgs	IP65